

- **Low-Cost TV Color-Burst Crystal Sine-Wave Input Produces Highly Accurate and Stable Tones**
- **Device Powered Directly by Telephone or Small Batteries**
- **Keyboard or Electronic Input Capability**
- **Dual-Tone and Single-Tone Capability**
- **Minimal Standby Power Requirement**
- **Total Harmonic Distortion Meets EIA Standard RS-470**
- **PEP3 Processing Available**
- **Wide Supply-Voltage Range**
- **Minimal External Parts Required**
- **Single-Tone Production Can be Inhibited**
- **Separate Tone Enable Provided**
- **Auxiliary Switching Bipolar Transistor Available**
- **Designed to be Interchangeable with Mostek MK5089**

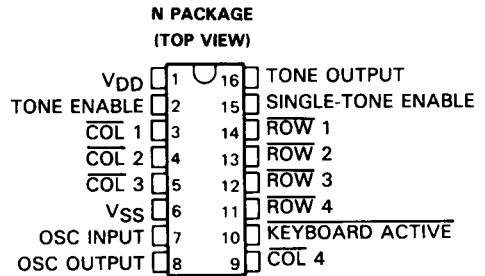

NOT RECOMMENDED FOR NEW DESIGN



Caution. These devices have limited built-in gate protection. The leads should be shorted together or the device placed in conductive foam during storage or handling to prevent electrostatic damage to the MOS gates.

description

The TCM5089 tone encoder is a CMOS integrated circuit designed specifically to generate the dial tones used in dual-tone telephone dialing systems. It requires a sine-wave input normally supplied by a low-cost TV color-burst crystal at 3.579545 MHz to generate eight different audio sinusoidal frequencies. With this input the encoder generates dial tones that are very low in total harmonic distortion and comply with standard Dual-Tone Multi-Frequency (DTMF) specifications without any need for frequency adjustment.

When generating a dual-tone signal, the encoder generates one column tone and one row tone and adds them for its output. The table below presents the frequencies produced by the tone encoder with the 3.579545-MHz TV-crystal signal input. Any deviation in this frequency will be reflected in the frequency output. The tolerance of the crystal is normally 0.02%.

| TONE | DTMF STANDARD (Hz) | ENCODER OUTPUT* (Hz) | ERROR FROM STANDARD* (%) |
|----------|--------------------------|----------------------------|--------------------------------|
| Row 1 | 697 | 701.3 | +0.62 |
| Row 2 | 770 | 771.4 | +0.19 |
| Row 3 | 852 | 857.2 | +0.61 |
| Row 4 | 941 | 935.1 | -0.63 |
| Column 1 | 1209 | 1215.9 | +0.57 |
| Column 2 | 1336 | 1331.7 | -0.32 |
| Column 3 | 1477 | 1471.9 | -0.35 |
| Column 4 | 1633 | 1645 | +0.73 |

*Using an input signal from a 3.579545-MHz crystal.

PRODUCTION DATA documents contain information current as of publication date. Products conform to specifications per the terms of Texas Instruments standard warranty. Production processing does not necessarily include testing of all parameters.



POST OFFICE BOX 655303 • DALLAS, TEXAS 75285

Copyright © 1990, Texas Instruments Incorporated

TCM5089 TONE ENCODER

operation

keyboard and electronic inputs

The specific tone or tones generated are determined by inputs designated $\overline{\text{ROW}}$ 1 through $\overline{\text{ROW}}$ 4 and COLUMN 1 through COLUMN 4. These input levels are normally received from a 2-of-8 DTMF (DPST) keyboard or from an electronic circuit. Unlike dynamic or scanned inputs, the static inputs of the TCM5089 do not generate any noise. See function table for input and output description.

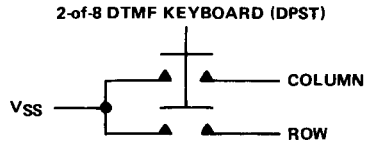

single-tone enable input

This inhibits the generation of single tones when taken low or left open. However, all other chip functions remain unchanged. If the input is high, single-tone operation is enabled.

tone enable input

The tone enable input, when low, disables the tone output of the encoder. Other chip functions remain unchanged.

keyboard active output

This output provides for switching of an external receiver, transmitter, or other functions. The output is low whenever one or more column inputs are active and at a high impedance when all column inputs are inactive.

functional block diagram

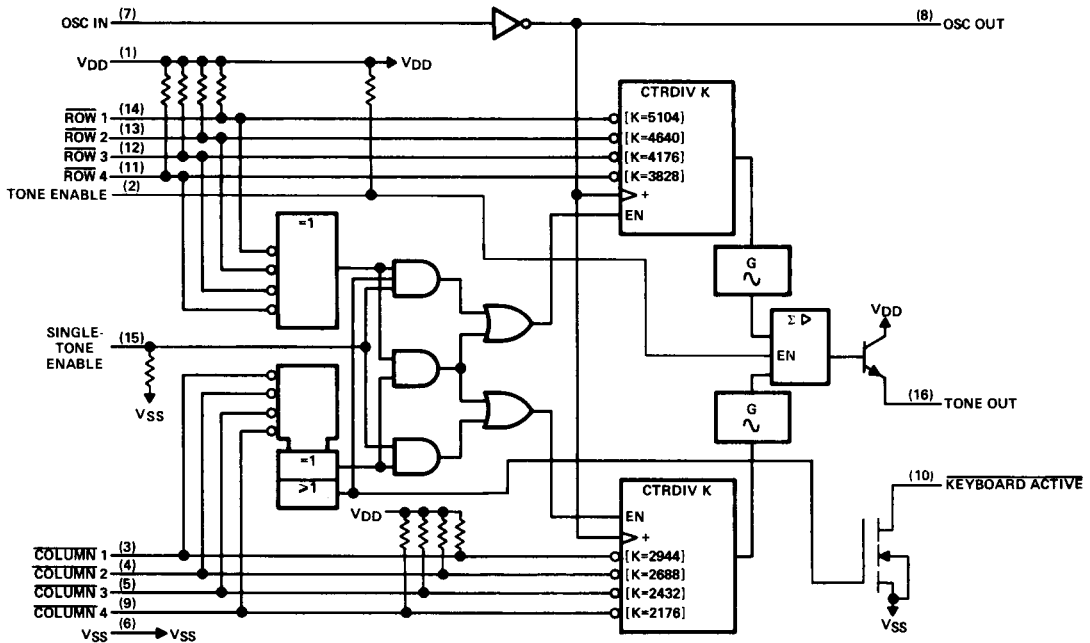

**TEXAS
INSTRUMENTS**

TONE ENCODER FUNCTION TABLE

| INPUT COMBINATIONS† | TONE OUTPUT | | | KEYBOARD ACTIVE OUTPUT |
|-------------------------------------|--|--|----------------------------|------------------------|
| | PIN 2 OPEN‡ PIN 15 at V _{DD} ‡ | PIN 2 OPEN‡ PIN 15 at V _{SS} ‡ | PIN 2 AT V _{SS} ‡ | |
| 0 rows 0 Columns | 0 | 0 | 0 | Hi-Z |
| 1 row 1 column | Row and column | Row and column | 0 | L |
| 2 or more rows 1 column | column | 0 | 0 | L |
| 1 row 2 or more columns | Row | 0 | 0 | L |
| 2 or more rows 2 or more columns | 0 | 0 | 0 | L |
| 0 rows 1 column | Column | 0 | 0 | L |
| 0 rows 2 or more columns | 0 | 0 | 0 | L |
| 1 or more rows 0 columns | 0 | 0 | 0 | Hi-Z |

†An inactive level can be produced by an open circuit. Under voltage-level control, row and column inputs will be active when low as defined by V_{IL} in recommended operating conditions.

‡Pin 15 is the single-tone enable input; Pin 2 is the tone-enable input.

absolute maximum ratings over operating free-air temperature range (unless otherwise noted)

| | |
|--|-----------------------------------|
| Supply voltage V _{DD} (see Note 1) | 13.5 V |
| Input voltage range | -0.3 V to V _{DD} + 0.3 V |
| Output voltage range | -0.3 V to V _{DD} + 0.3 V |
| Continuous power dissipation at 25°C free-air temperature (see Note 2) | 1150 mW |
| Operating free-air temperature range | -30°C to 70°C |
| Storage temperature range | -55°C to 150°C |

- NOTES: 1. All voltage values are with respect to the V_{SS} terminal.
2. For operation above 25°C see the Dissipation Derating Curve.

DISSIPATION DERATING CURVE

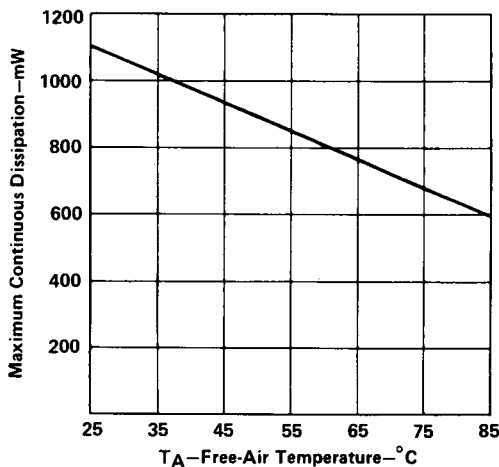

TCM5089

TONE ENCODER

recommended operating conditions

| | MIN | NOM | MAX | UNIT |
|---|--------------|-----|--------------|------|
| Supply voltage, V_{DD} | 3 | | 10 | V |
| High-level input voltage, any input, V_{IH} | 0.7 V_{DD} | | V_{DD} | V |
| Low-level input voltage, any input, V_{IL} | V_{SS} | | 0.3 V_{DD} | V |
| Operating free-air temperature, T_A | -30 | | 70 | °C |

electrical characteristics over operating free-air temperature range (unless otherwise noted)

| PARAMETER | | TEST CONDITIONS | MIN | TYP | MAX | UNIT |
|---|---|--------------------------------------|------|-----|-----|---------------|
| Input resistance, single-tone input to V_{SS} | | | 20 | | 100 | k Ω |
| I_{OH} | High-level output current, keyboard active output | $V_O = 5\text{ V}^\dagger$ | | | 2 | μA |
| I_{OL} | Low-level output current, keyboard active output | $V_O = 0.5\text{ V}^\dagger$ | -500 | | | μA |
| I_{DDstby} | Standby power supply current | $V_{DD} = 10\text{ V}$, See Note 3 | | | 200 | μA |
| I_{DDop} | Operating power supply current | $V_{DD} = 3.5\text{ V}$, See Note 4 | | | 2 | mA |

operating characteristics over recommended ranges of operating free-air temperature and supply voltage (unless otherwise noted)

| PARAMETER | | TEST CONDITIONS [‡] | MIN | TYP | MAX | UNIT |
|--|-------------|--|-----|-----|-----|------|
| Output rms voltage | Row tone | $V_{DD} = 3.5\text{ V}$, $R_L = 10\text{ k}\Omega$ | 235 | | 365 | mV |
| | Column tone | | 275 | | 516 | |
| Preemphasis (column-tone to row-tone) | | $R_L = 10\text{ k}\Omega$ | 2 | | 3.5 | dB |
| Dual-tone output distortion (see Note 5) | | $V_{DD} \geq 3.5\text{ V}$, $R_L = 10\text{ k}\Omega$ | | | -20 | dB |
| Quiescent tone-output power | | $R_L = 10\text{ k}\Omega$ | | | -80 | dBm |
| Tone-output rise time (see Note 6) | | | | 2.8 | 5 | ms |

[†] V_O is the dc bias on the keyboard-active output.

[‡]Crystal parameters are as follows: $f = 3.579545\text{ MHz} \pm 0.02\%$, $R_S \leq 100\ \Omega$, $C_L = 18\text{ pF}$, $C_M = 0.02\text{ pF}$, and $L_M = 96\text{ mH}$.

NOTES: 3. Standby power supply current is measured with no inputs activated.

4. Operating current is measured with all outputs unloaded, one row input and one column input active, and normal oscillator input.

5. Distortion is expressed as the ratio of total out-of-band power relative to the total fundamental power for the dual tone.

6. This is the time required for the output to change from its quiescent value to 90% of its final rms value.



output waveforms

Typical row and column staircase approximations of sinusoidal outputs are shown in Figures 1 and 2. The row and column outputs are added together resulting in a typical dual-tone waveform as shown in Figure 3. Spectral analysis of this dual-tone waveform shows that all harmonic and intermodulation distortions are typically 30 dB below the strongest column-tone fundamental.

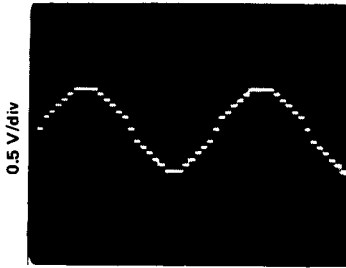

0.2 ms/div
FIGURE 1

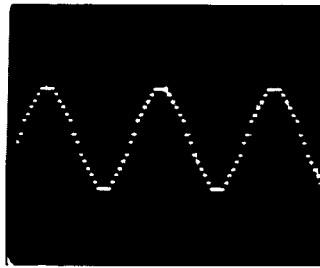

0.2 ms/div
FIGURE 2

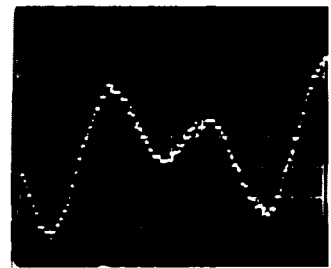

0.2 ms/div
FIGURE 3

distortion considerations

The following formula is used to calculate the total harmonic distortion of a single row or a single column:

$$THD = \left(\frac{\sqrt{V_{2f}^2 + V_{3f}^2 + V_{4f}^2 + V_{5f}^2 + \dots + V_{nf}^2}}{V_{1f}} \right) \times 100\%$$

where V_{2f} is the second harmonic of the fundamental frequency V_{1f} waveform and so on. The dual-tone total harmonic distortion is:

$$THD = \left(\frac{\sqrt{V_{2R}^2 + V_{3R}^2 + \dots + V_{nR}^2 + V_{2C}^2 + \dots + V_{nC}^2 \pm V_{IMD}^2}}{\sqrt{V_{FR}^2 + V_{FC}^2}} \right) \times 100\%$$

where V_{FR} and V_{FC} are the row and column fundamental frequency waveforms, and V_{2R} and V_{2C} , etc. are the corresponding harmonics.

The total intermodulation distortion is:

$$V_{IMD}^2 = (V_{1R} + V_{1C})^2 + (V_{1R} - V_{1C})^2 + \dots + (V_{nR} + V_{nC})^2 + (V_{nR} - V_{nC})^2$$

A relatively simple method of distortion measurement uses a spectrum analyzer to relate the harmonics to the fundamental frequency waveform. The tone encoder spectrum indicates the harmonics and intermodulation distortion at least 30 dB down relative to the column tone.

Another method for distortion measurement of the dual-tone waveform is to compare the total power in the fundamental frequencies with the total power in the various harmonics plus intermodulation on a signal analyzer. The encoders provide an output distortion of -20 dB maximum when operated between 3.5 volts and 10 volts. If operated between 3 volts and 3.5 volts, some clipping occurs at the output causing the distortion to exceed the -20 dB level.

APPLICATION INFORMATION

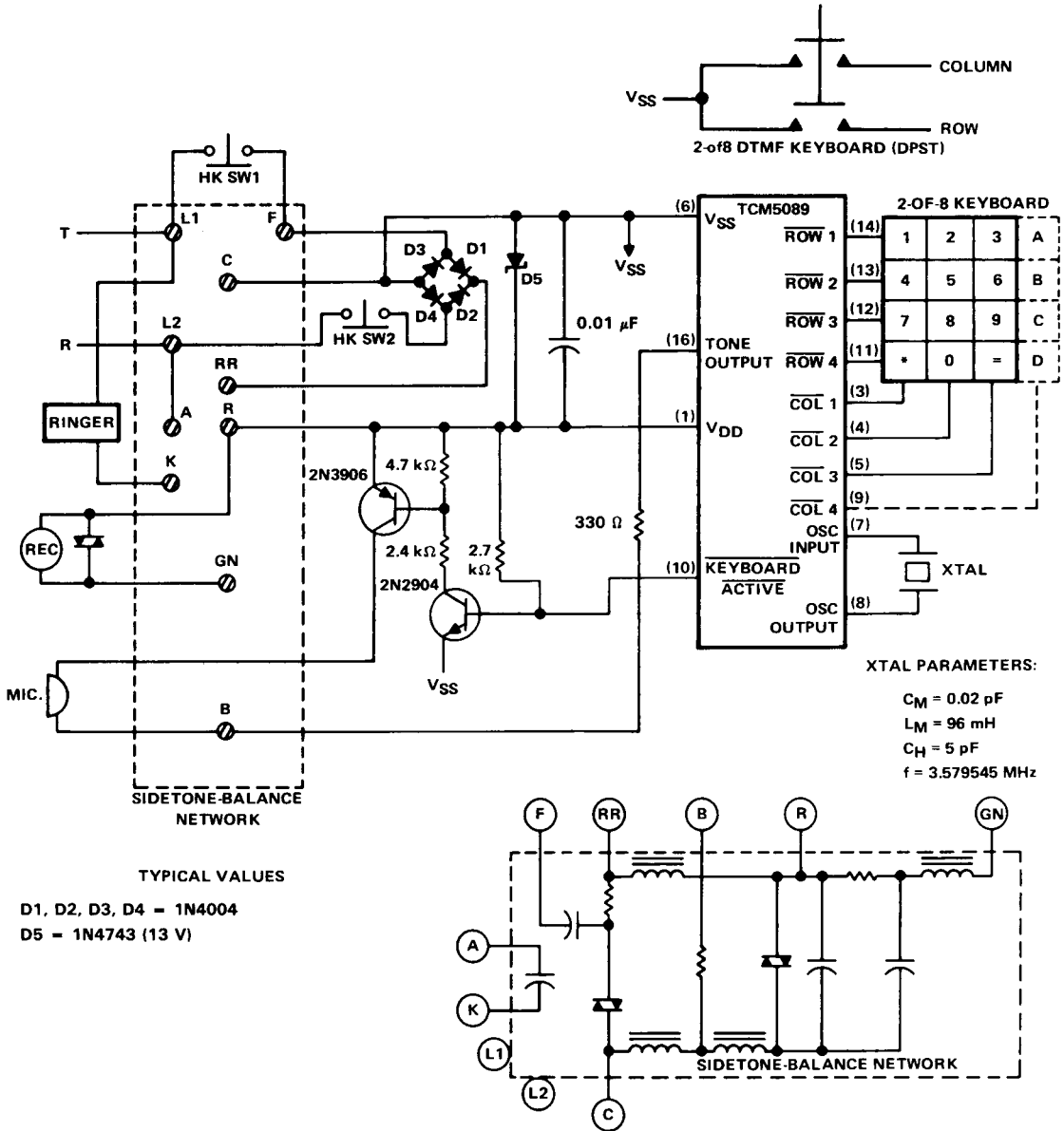

FIGURE 4. TYPICAL APPLICATION USING HYBRID COIL SIDETONE-BALANCE NETWORK, ELECTRONIC SWITCHING, AND LOW-COST (CLASS A) KEYBOARD